

Electricity and New Energy

Single-Phase AC Power Circuits

Course Sample

594089

Order no.: 594089 (Printed version) 594404 (CD-ROM)

First Edition

Revision level: 06/2018

By the staff of Festo Didactic

© Festo Didactic Ltée/Ltd, Quebec, Canada 2018

Internet: www.festo-didactic.com

e-mail: did@de.festo.com

Printed in Canada

All rights reserved

ISBN 978-2-89747-806-3 (Printed version)

ISBN 978-2-89747-807-0 (CD-ROM)

Legal Deposit – Bibliothèque et Archives nationales du Québec, 2018

Legal Deposit – Library and Archives Canada, 2018

The purchaser shall receive a single right of use which is non-exclusive, non-time-limited and limited geographically to use at the purchaser's site/location as follows.

The purchaser shall be entitled to use the work to train his/her staff at the purchaser's site/location and shall also be entitled to use parts of the copyright material as the basis for the production of his/her own training documentation for the training of his/her staff at the purchaser's site/location with acknowledgement of source and to make copies for this purpose. In the case of schools/technical colleges, training centers, and universities, the right of use shall also include use by school and college students and trainees at the purchaser's site/location for teaching purposes.

The right of use shall in all cases exclude the right to publish the copyright material or to make this available for use on intranet, Internet, and LMS platforms and databases such as Moodle, which allow access by a wide variety of users, including those outside of the purchaser's site/location.

Entitlement to other rights relating to reproductions, copies, adaptations, translations, microfilming, and transfer to and storage and processing in electronic systems, no matter whether in whole or in part, shall require the prior consent of Festo Didactic.

















Information in this document is subject to change without notice and does not represent a commitment on the part of Festo Didactic. The Festo materials described in this document are furnished under a license agreement or a nondisclosure agreement.

Festo Didactic recognizes product names as trademarks or registered trademarks of their respective holders.

All other trademarks are the property of their respective owners. Other trademarks and trade names may be used in this document to refer to either the entity claiming the marks and names or their products. Festo Didactic disclaims any proprietary interest in trademarks and trade names other than its own.

Safety and Common Symbols

The following safety and common symbols may be used in this course and on the equipment:

| Symbol | Description |
|---|---|
|  | DANGER indicates a hazard with a high level of risk which, if not avoided, will result in death or serious injury. |
|  | WARNING indicates a hazard with a medium level of risk which, if not avoided, could result in death or serious injury. |
|  | CAUTION indicates a hazard with a low level of risk which, if not avoided, could result in minor or moderate injury. |
|  | CAUTION used without the <i>Caution, risk of danger</i> sign  , indicates a hazard with a potentially hazardous situation which, if not avoided, may result in property damage. |
|  | Caution, risk of electric shock |
|  | Caution, hot surface |
|  | Caution, risk of danger. Consult the relevant user documentation. |
|  | Caution, lifting hazard |
|  | Caution, belt drive entanglement hazard |
|  | Caution, chain drive entanglement hazard |
|  | Caution, gear entanglement hazard |
|  | Caution, hand crushing hazard |
|  | Notice, non-ionizing radiation |
|  | Consult the relevant user documentation. |
|  | Direct current |
|  | Alternating current |

Safety and Common Symbols











| Symbol | Description |
|---|--|
|  | Both direct and alternating current |
|  | Three-phase alternating current |
|  | Earth (ground) terminal |
|  | Protective conductor terminal |
|  | Frame or chassis terminal |
|  | Equipotentiality |
|  | On (supply) |
|  | Off (supply) |
|  | Equipment protected throughout by double insulation or reinforced insulation |
|  | In position of a bi-stable push control |
|  | Out position of a bi-stable push control |

Table of Contents

| | |
|--|-----------|
| Preface | XI |
| About This Course | XIII |
| To the Instructor | XV |
| Unit 1 Alternating Current..... | 1 |
| DISCUSSION OF FUNDAMENTALS..... | 1 |
| DC circuits versus ac circuits | 1 |
| Alternating current (ac) and ac voltage | 2 |
| Alternating current and ac voltage supplied by public power distribution utilities | 2 |
| Safety rules | 3 |
| | |
| Ex. 1-1 The Sine Wave | 5 |
| DISCUSSION | 5 |
| Relationship between a rotating phasor and a sine wave | 5 |
| Period and frequency of a sinusoidal voltage or current..... | 8 |
| Amplitude and instantaneous value of a sinusoidal voltage or current | 8 |
| Effective or root-mean-square (rms) value and heating capacity | 10 |
| Effective (rms) value of a sinusoidal voltage or current | 10 |
| PROCEDURE | 11 |
| Setup and connections..... | 11 |
| Measuring voltage, current, and frequency in an ac circuit | 13 |
| Relationship between frequency and period..... | 15 |
| Measuring voltage, current, and frequency in a series ac circuit | 16 |
| CONCLUSION | 19 |
| REVIEW QUESTIONS..... | 19 |
| | |
| Ex. 1-2 Phase Angle and Phase Shift | 21 |
| DISCUSSION | 21 |
| Phase angle | 21 |
| Phase shift..... | 23 |
| PROCEDURE | 25 |
| Setup and connections..... | 25 |
| Measuring the phase shift between two voltage sine waves in a resistor-inductor (RL) circuit..... | 26 |
| Measuring the phase shift between two voltage sine waves in a resistor-capacitor (RC) circuit | 30 |
| CONCLUSION | 34 |
| REVIEW QUESTIONS..... | 34 |

Table of Contents

| | | |
|----------------|---|-----------|
| Ex. 1-3 | Instantaneous Power and Average Power | 37 |
| | DISCUSSION | 37 |
| | Instantaneous power | 37 |
| | Average power | 38 |
| | Rationale behind rms values | 39 |
| | PROCEDURE | 40 |
| | Setup and connections | 40 |
| | Average power measurements | 41 |
| | Rationale behind rms values | 44 |
| | CONCLUSION | 46 |
| | REVIEW QUESTIONS | 46 |
| Unit 2 | Resistance, Reactance, and Impedance | 49 |
| | DISCUSSION OF FUNDAMENTALS | 49 |
| | Introduction to inductors and capacitors | 49 |
| | Distinction between resistance, reactance, and impedance | 50 |
| Ex. 2-1 | Inductive Reactance | 51 |
| | DISCUSSION | 51 |
| | Inductors and inductive reactance | 51 |
| | Inductive phase shift | 52 |
| | PROCEDURE | 52 |
| | Setup and connections | 52 |
| | Inductance and inductive reactance | 54 |
| | Effect of frequency on the inductive reactance | 56 |
| | Measuring the inductive phase shift | 57 |
| | CONCLUSION | 59 |
| | REVIEW QUESTIONS | 60 |
| Ex. 2-2 | Capacitive Reactance | 61 |
| | DISCUSSION | 61 |
| | Capacitors and capacitive reactance | 61 |
| | Capacitive phase shift | 62 |
| | PROCEDURE | 62 |
| | Setup and connections | 62 |
| | Capacitance and capacitive reactance | 64 |
| | Effect of the frequency on the capacitive reactance | 66 |
| | Measuring the capacitive phase shift | 67 |
| | CONCLUSION | 69 |
| | REVIEW QUESTIONS | 70 |

Table of Contents

| | | |
|----------------|---|-----------|
| Ex. 2-3 | Impedance | 71 |
| | DISCUSSION | 71 |
| | Phasor diagrams related to resistors, inductors, and capacitors | 71 |
| | Phasor diagram related to a resistor | 72 |
| | Phasor diagram related to an inductor | 72 |
| | Phasor diagram related to a capacitor | 73 |
| | Equivalent reactance of series-connected reactive components | 73 |
| | Impedance of resistors, inductors, and capacitors connected in series | 75 |
| | Impedance of resistors, inductors, and capacitors connected in parallel | 78 |
| | PROCEDURE | 79 |
| | Setup and connections | 79 |
| | Equivalent reactance of a series LC circuit | 80 |
| | Impedance of a series RL circuit | 83 |
| | Impedance of a series RC circuit | 84 |
| | Impedance of a series RLC circuit | 86 |
| | Impedance of a parallel RL circuit | 87 |
| | Impedance of a parallel RC circuit | 88 |
| | CONCLUSION | 90 |
| | REVIEW QUESTIONS | 90 |
| Unit 3 | Power in AC Circuits | 95 |
| | DISCUSSION OF FUNDAMENTALS | 95 |
| | Introduction to active, reactive, and apparent power | 95 |
| Ex. 3-1 | Active and Reactive Power | 97 |
| | DISCUSSION | 97 |
| | Active power in a resistor | 97 |
| | Reactive power in an inductor | 98 |
| | Reactive power in a capacitor | 99 |
| | Power Meter | 100 |
| | PROCEDURE | 100 |
| | Setup and connections | 101 |
| | Active power in a resistor | 102 |
| | Reactive power in an inductor | 104 |
| | Reactive power in a capacitor | 107 |
| | CONCLUSION | 109 |
| | REVIEW QUESTIONS | 109 |

Table of Contents

| | | |
|----------------|---|------------|
| Ex. 3-2 | Apparent Power and the Power Triangle | 111 |
| | DISCUSSION | 111 |
| | Phasor diagrams related to active and reactive power | 111 |
| | Phasor diagram related to the active power in a resistor | 111 |
| | Phasor diagram related to the reactive power in an inductor... | 112 |
| | Phasor diagram related to the reactive power in a capacitor... | 112 |
| | Apparent power | 113 |
| | Power triangle | 114 |
| | Power factor | 114 |
| | PROCEDURE | 115 |
| | Setup and connections..... | 115 |
| | Total reactive power in a circuit..... | 116 |
| | Apparent power, power factor, and power triangle | 119 |
| | CONCLUSION | 123 |
| | REVIEW QUESTIONS..... | 123 |
| Unit 4 | AC Circuits Analysis | 129 |
| | DISCUSSION OF FUNDAMENTALS..... | 129 |
| | Introduction to circuit analysis | 129 |
| | Circuit analysis methods | 129 |
| Ex. 4-1 | Solving Simple AC Circuits Using Circuit Impedance | |
| | Calculation..... | 131 |
| | DISCUSSION | 131 |
| | Solving simple parallel circuits | 131 |
| | Example | 132 |
| | Solving simple series circuits | 133 |
| | Example | 134 |
| | PROCEDURE | 135 |
| | Setup and connections..... | 135 |
| | Solving a simple parallel ac circuit | 136 |
| | Solving a simple series ac circuit | 138 |
| | CONCLUSION | 141 |
| | REVIEW QUESTIONS..... | 141 |
| Ex. 4-2 | Solving AC Circuits Using the Power Triangle Method..... | 143 |
| | DISCUSSION | 143 |
| | Solving ac circuits using the power triangle method | 143 |
| | Example | 144 |
| | PROCEDURE | 146 |
| | Setup and connections..... | 147 |
| | Solving an ac circuit using the power triangle method..... | 148 |
| | CONCLUSION | 152 |
| | REVIEW QUESTIONS..... | 152 |

Table of Contents

| | |
|--|------------|
| Appendix A Equipment Utilization Chart..... | 159 |
| Appendix B Glossary of New Terms..... | 161 |
| Appendix C Impedance Table for the Load Modules | 165 |
| Appendix D Vectorial Calculations | 167 |
| Vectorial division | 168 |
| Vectorial multiplication | 169 |
| Appendix E Circuit Diagram Symbols | 171 |
| Appendix F Course Completion with the AC 230V/DC 325V Variable Power Supply | 177 |
| Index of New Terms | 179 |
| Bibliography..... | 181 |

Preface

Electrical energy is part of our life since more than a century and the number of applications using electric power keeps increasing. This phenomenon is illustrated by the steady growth in electric power demand observed worldwide. In reaction to this phenomenon, the production of electrical energy using renewable natural resources (e.g., wind, sunlight, rain, tides, geothermal heat, etc.) has gained much importance in recent years since it helps to meet the increasing demand for electric power and is an effective means of reducing greenhouse gas (GHG) emissions.

To help answer the increasing needs for training in the wide field of electrical energy, Festo Didactic developed a series of modular courses. These courses are shown below as a flow chart, with each box in the flow chart representing a course.

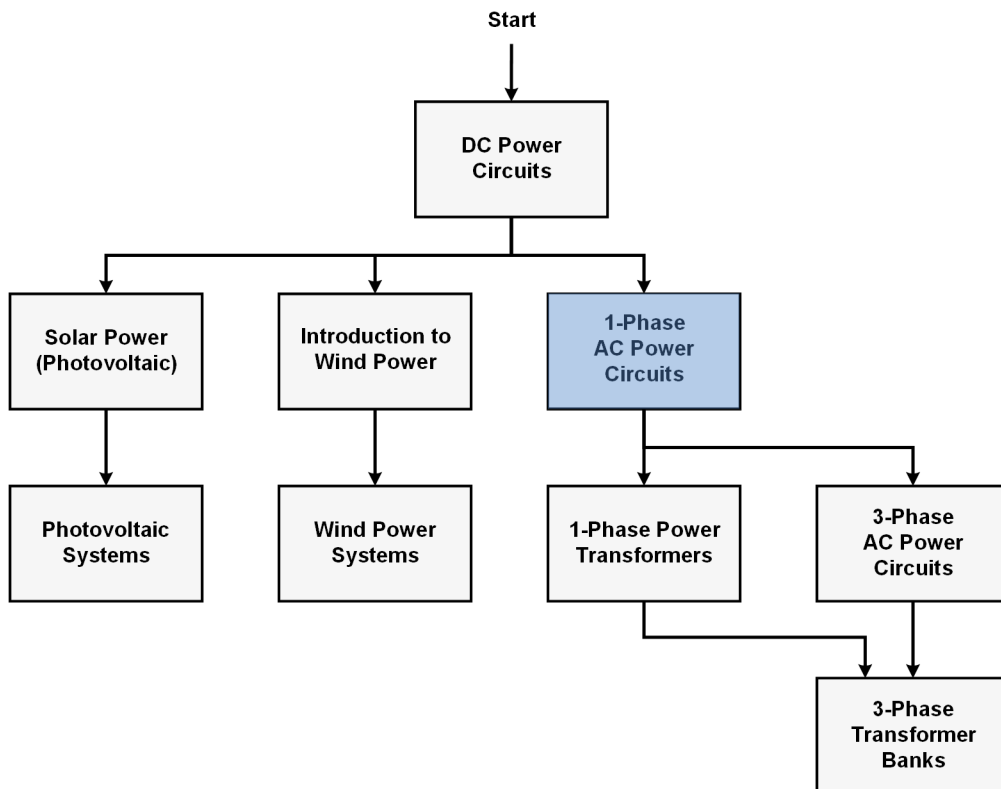

Festo Didactic courses in electrical energy.

Teaching includes a series of courses providing in-depth coverage of basic topics related to the field of electrical energy such as dc power circuits, ac power circuits, and power transformers. Other courses also provide in-depth coverage of solar power and wind power. Finally, two courses deal with photovoltaic systems and wind power systems, with focus on practical aspects related to these systems.

We invite readers of this manual to send us their tips, feedback, and suggestions for improving the book.

Please send these to did@de.festo.com.

The authors and Festo Didactic look forward to your comments.

About This Course

Alternating-current (ac) power systems began to develop quickly in the late 19th century, following key developments in the field of electricity, mainly the invention of the polyphase system of electrical distribution by scientist Nikola Tesla, and the development of mathematical analysis of electricity by Charles Steinmetz, James Clerk Maxwell, and William Thomson (Lord Kelvin).

The main advantage of ac power systems is that high amounts of power can be transmitted efficiently over long transmission lines. Step-up transformers are used at the ac power generating point to increase the voltage and decrease the current. The power lost as heat in the resistance of a transmission line increases by the square of the current. Therefore, ac power is transmitted at very high voltages and low currents to reduce power losses in the line resistance to a minimum. At the receiving end of the line, step-down transformers reduce the voltage and increase the current to levels compatible with residential or industrial equipment.

Today ac power systems are used throughout the world for driving motors and powering electric equipment in transport, heating, lighting, communications, and computation.

This course, *Single-Phase AC Power Circuit*, introduces students to the fundamentals of alternating current, such as the sine wave, period and frequency, phase angle and phase shift, instantaneous and average power, etc. Students then become familiar with the inductor and capacitor. The course continues with more advanced topics such as the impedance, active power, reactive power, apparent power, and power triangle. The course concludes by teaching students how to solve ac power circuits using the impedance calculation method or the power triangle method.



Most lighting in urban centers is powered using single-phase alternative current.

About This Course

Completion of the hands-on exercises in the present course requires the [4 Quadrant Power Supply and Dynamometer Controller](#). In these exercises, the [4 Quadrant Power Supply and Dynamometer Controller](#) is mostly used as a variable voltage and frequency, ac power source. The [4 Quadrant Power Supply and Dynamometer Controller](#) can be replaced with the [AC 230V/DC 325V Variable Power Supply](#) (variable-voltage, ac/dc power source) and two multimeters to perform the majority of the manipulations in the hands-on exercises of the present course. Appendix F shows how to use the [AC 230V/DC 325V Variable Power Supply](#) and the two multimeters in place of the [4 Quadrant Power Supply and Dynamometer Controller](#) to perform the hands-on exercises.

Safety considerations

Safety symbols that may be used in this course and on the equipment are listed in the Safety and Common Symbols table at the beginning of this document.

Safety procedures related to the tasks that you will be asked to perform are indicated in each exercise.

Make sure that you are wearing appropriate protective equipment when performing the tasks. You should never perform a task if you have any reason to think that a manipulation could be dangerous for you or your teammates.

Prerequisite

As a prerequisite to this course, you should have completed course *DC Power Circuits*.

Systems of units

Units are expressed using the International System of Units (SI).

To the Instructor

You will find in this Instructor version of the course all the elements included in the Student version of the course together with the answers to all questions, results of measurements, graphs, explanations, suggestions, and, in some cases, instructions to help you guide the students through their learning process. All the information that applies to you is placed between markers and appears in red.

Accuracy of measurements

The numerical results of the hands-on exercises may differ from one student to another. For this reason, the results and answers given in this course should be considered as a guide. Students who correctly performed the exercises should expect to demonstrate the principles involved and make observations and measurements similar to those given as answers.

Equipment installation and use

In order for students to be able to safely perform the hands-on exercises in this course, the equipment must have been properly installed, i.e., according to the instructions given in the accompanying Safety Instructions and Commissioning manual. Also, the students must familiarize themselves with the safety directives provided in the Safety Instructions and Commissioning manual and observe these directives when using the equipment.

Sample
Extracted from
Instructor Guide

Phase Angle and Phase Shift

EXERCISE OBJECTIVE

When you have completed this exercise, you will know what a phase angle is and how the phase angle modifies the initial displacement of a sine wave. You will be able to determine the phase shift between two sine waves, either by comparing their phase angles or by determining their separation in time. You will also know how to distinguish a leading phase shift from a lagging phase shift.

DISCUSSION OUTLINE

The Discussion of this exercise covers the following points:

- Phase angle
- Phase shift

DISCUSSION

Phase angle

As you have seen in Exercise 1-1, the graphical representation of a sine wave can be expressed by the following equation:

$$a(t) = A \sin(\omega t) \quad (1-8)$$

where $a(t)$ is the instantaneous value of the sine wave at a given instant t .

A is the amplitude of the sine wave.

ω is the angular velocity, expressed in radians per second (rad/s).

t is the time, expressed in seconds (s).

This equation assumes that the sine wave cycle begins at the exact moment when $t = 0$ (as is shown in Figure 1-10). As you will see later, this is not always the case. To represent the initial position of the sine wave, the notion of **phase angle** θ is introduced in the equation below:

$$a(t) = A \sin(\omega t + \theta) \quad (1-9)$$

where θ is the phase angle of the sine wave, expressed in degrees ($^\circ$) or radians (rad).

From Equation (1-9), it is easy to observe that the initial value (i.e., the value at $t = 0$) of the sine wave depends entirely on the phase angle θ because the term ωt equals 0 at $t = 0$. In other words, the phase angle θ determines by how much the value of a sine wave differs from 0 at time $t = 0$, and thus, the position in time of the sine wave.

Figure 1-10 shows a sine wave with a phase angle θ of 0° . The initial value of this sine wave is 0 because $A \sin(\omega \cdot 0 + 0) = 0$. This sine wave is identical to those seen in Exercise 1-1, as a phase angle value of 0° was implied by the absence of θ in the equations given in Exercise 1-1.

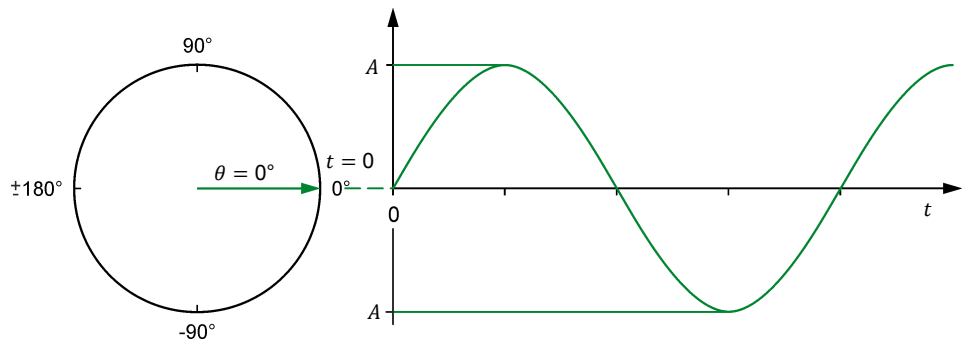

Figure 1-10. Sine wave with a phase angle θ of 0° .

Figure 1-11 shows a sine wave with a phase angle θ of 45° . As you can see from the figure, a positive phase angle (0° to 180°) results in the sine wave having a positive instantaneous value when $t = 0$. In other words, a positive phase angle shifts the sine wave toward the left, i.e., advances the sine wave in time.

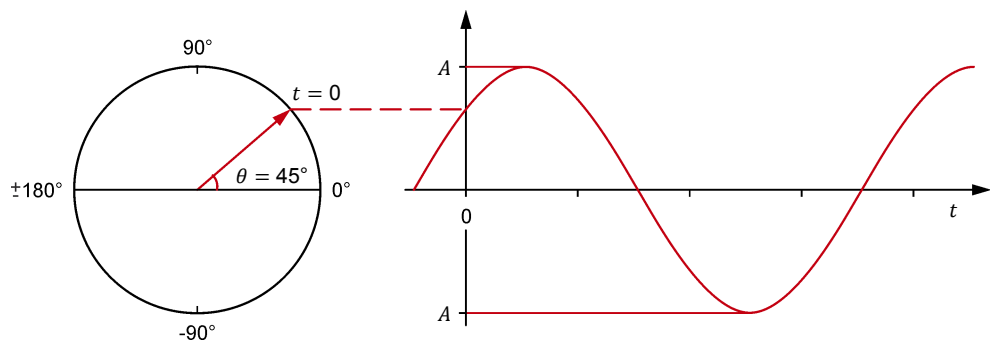

Figure 1-11. Sine wave with a phase angle θ of 45° .

Figure 1-12 shows a sine wave with a phase angle θ of -60° . A negative phase angle (0° to -180°) results in the sine wave having a negative instantaneous value when $t = 0$. In other words, a negative phase angle shifts the sine wave toward the right, i.e., delays the sine wave in time.

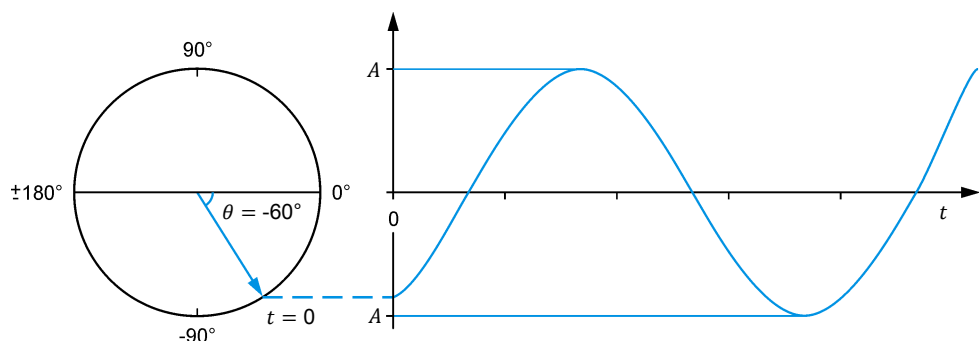

Figure 1-12. Sine wave with a phase angle θ of -60° .

Figure 1-10 to Figure 1-12 also show the phasor representations of the sine waves at time $t = 0$. Notice that, in each figure, the vertical distance between the tip of the rotating phasor representing the sine wave matches the instantaneous value of the sine wave at $t = 0$.

Phase shift

When comparing two sine waves having the same frequency, the difference between their respective phase angles is called the **phase shift** and is expressed in degrees ($^{\circ}$) or radians (rad). The magnitude of the phase shift indicates the extent of separation in time between the two sine waves, while the polarity of the phase shift (positive or negative) indicates the relationship in time between the two sine waves (**leading** or **lagging**). The sine wave amplitude value has no effect on the phase shift, as it does not change the period nor the frequency of the sine wave. Sine waves with different frequencies and, as an extension, different periods, cannot be compared by using their phase angles as their cycles do not correspond.

The phase shift between two sine waves is expressed as an angle representing a portion of a complete cycle of the sine waves. One of the two sine waves is used as the reference for phase shift measurements. The phase shift is calculated by subtracting the phase angle $\theta_{Ref.}$ of the reference sine wave from the phase angle θ of the sine wave of interest. This is written as an equation below.

$$\text{Phase shift} = \theta - \theta_{Ref.} \quad (1-10)$$

where θ is the phase angle of the sine wave of interest, expressed in degrees ($^{\circ}$) or radians (rad).

$\theta_{Ref.}$ is the phase angle of the reference sine wave, expressed in degrees ($^{\circ}$) or radians (rad).

Figure 1-13 is an example showing how the phase shift between two sine waves (X and Y) can be calculated using their phase angles.

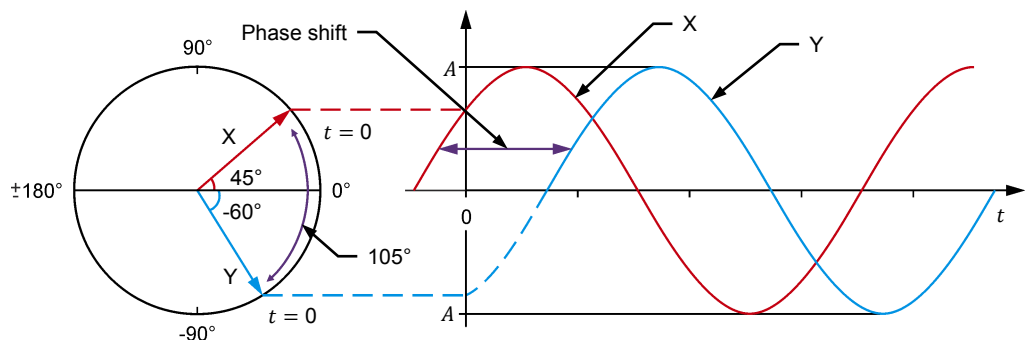

Figure 1-13. Phase shift between two sine waves with phase angles of 45° and -60° .

In the figure, sine wave X has a phase angle θ of 45° , while sine wave Y has a phase angle θ of -60° . Depending on which sine wave is used as the reference, the phase shift can be $+105^{\circ}$ or -105° . When sine wave X is considered as the reference, the phase shift of sine wave Y with respect to sine wave X is -105° ($-60^{\circ} - 45^{\circ} = -105^{\circ}$). The minus sign in this phase shift value indicates that sine wave Y lags reference sine wave X. For this reason, this phase shift value can also be expressed as 105° lagging. Conversely, when sine wave Y is considered as the reference, the phase shift of sine wave X with respect to sine wave Y is $+105^{\circ}$ ($45^{\circ} - (-60^{\circ}) = +105^{\circ}$). The plus sign in this phase shift value indicates that sine wave X leads reference sine wave Y. For this reason, this phase shift value can also be expressed as 105° leading. Note that whenever two sine waves have different phase angles, the phase shift value is not zero, and thus, these sine waves are said to be out of phase.

It is possible to determine the phase shift between two sine waves of the same frequency without knowing their respective phase angles θ . The following equation is used:

$$\text{Phase shift} = \frac{d}{T} \times 360^\circ = \frac{d}{T} \times 2\pi \text{ rad} \quad (1-11)$$

where d is the time interval between a given reference point on each of the two sine waves, expressed in seconds (s).

T is the period of the sine waves, expressed in seconds (s).

This equation shows in a concrete way why it is not possible to calculate the phase shift between two sine waves having different frequencies f , as a common period T ($T = 1/f$) is needed for the equation to be valid.

Consider, for example, the sine waves shown in Figure 1-14. Using Equation (1-11), the phase shift between the two sine waves is equal to:

$$\text{Phase shift} = \frac{d}{T} \times 360^\circ = \frac{3.33 \text{ ms}}{20.0 \text{ ms}} \times 360^\circ = 60^\circ$$

When sine wave 1 is used as the reference, the phase shift is lagging because sine wave 2 is delayed with respect to sine wave 1. Conversely, when sine wave 2 is considered as the reference, the phase shift is leading because sine wave 1 is in advance with respect to sine wave 2.

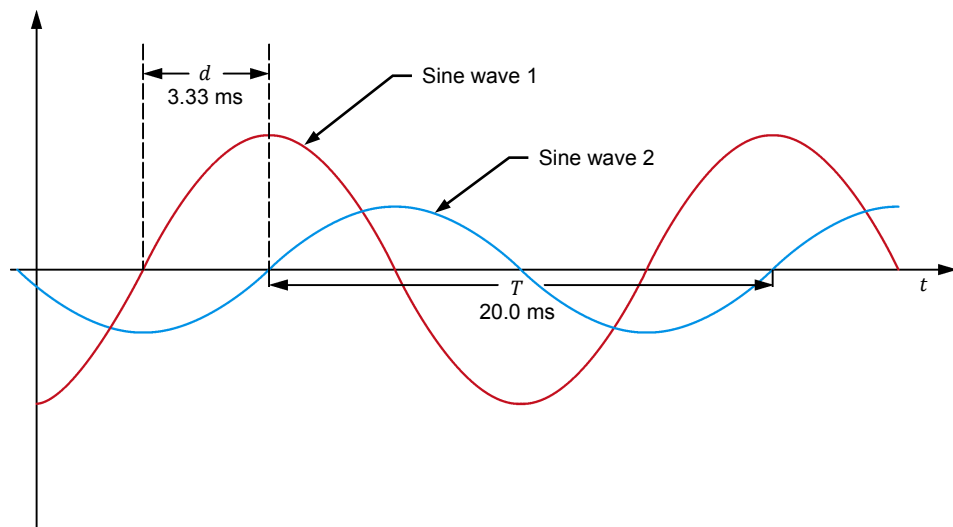

Figure 1-14. Phase shift between two sine waves having the same frequency.

PROCEDURE OUTLINE

The Procedure is divided into the following sections:

- Setup and connections
- Measuring the phase shift between two voltage sine waves in a resistor-inductor (RL) circuit
- Measuring the phase shift between two voltage sine waves in a resistor-capacitor (RC) circuit

PROCEDURE

WARNING



High voltages are present in this laboratory exercise. Do not make or modify any banana jack connections with the power on unless otherwise specified.

Setup and connections

In this section, you will connect an ac circuit containing an inductor and a resistor in series and set up the equipment to measure the source voltage U_S , as well as the voltage across the resistor U_R .

1. Refer to the Equipment Utilization Chart in Appendix A to obtain the list of equipment required to perform this exercise.



The 4 Quadrant Power Supply and Dynamometer Controller can be replaced with the AC 230V/DC 325V Variable Power Supply and two multimeters to perform the exercise. Appendix F shows how to use the AC 230V/DC 325V Variable Power Supply and the two multimeters in place of the 4 Quadrant Power Supply and Dynamometer Controller to perform the exercises.

2. Set up the equipment by performing the following tasks in the order they are listed.
 - Install the equipment required in the workstation.
 - Make the equipment earthing connections.
 - Connect the equipment to ac power outlets that are properly protected.
 - Connect the [Data Acquisition and Control Interface](#) to the [AC 24V Power Supply](#).
 - Turn on (i.e., unlock) electric power at your workstation, if applicable.
 - Turn the equipment on.
 - Set the [4 Quadrant Power Supply and Dynamometer Controller](#) for operation as a power supply.
 - Connect the equipment to USB ports of the host computer.
 - Turn the host computer on, then start the [LVDAC-EMS](#) software.



Refer to the procedure of Exercise 1-1 for detailed manipulations related to the tasks above, if necessary.

3. In [LVDAC-EMS](#), make sure that the [Data Acquisition and Control Interface](#) and the [4 Quadrant Power Supply and Dynamometer Controller](#) are detected. Make sure that the [Computer-Based Instrumentation](#) function for the [Data Acquisition and Control Interface](#) is available. Select the network voltage and frequency that correspond to the voltage and frequency of your local ac power network.

4. Set up the circuit shown in Figure 1-15. This circuit contains a resistor R and an inductor L . Inductors are studied in the next unit of this manual.

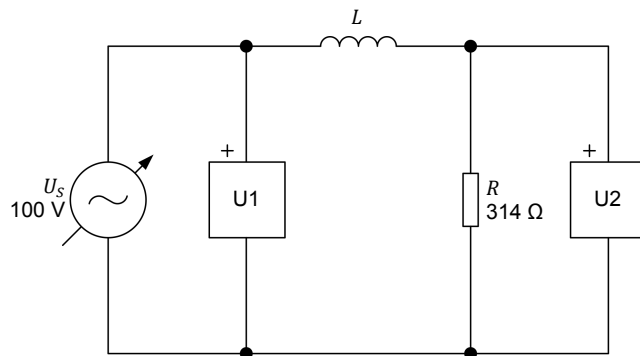

Figure 1-15. AC circuit with a resistor and an inductor.

The value of inductor L in the circuit of Figure 1-15 is referred to as the inductance and is expressed in henries (H). The inductance value to be used is 1.00 H.

Make the necessary connections and switch settings on the [Resistive Load](#) in order to obtain the resistance value required.



Appendix C of this manual lists the switch settings to implement on the [Resistive Load](#) in order to obtain various resistance values.

Make the necessary connections and switch settings on the [Inductive Load](#) in order to obtain the inductance value required.



If necessary, ask your instructor to assist you to obtain the inductance value required.

Use inputs $U1$ and $U2$ of the [Data Acquisition and Control Interface](#) to measure the source voltage U_s and the voltage across the resistor U_R , respectively.

5. In [LVDAC-EMS](#), make the settings required to make the [4 Quadrant Power Supply and Dynamometer Controller](#) operate as a variable voltage and frequency, ac power source. Then, set the ac power source as follows:
- Voltage: 100 V
 - Frequency: same as the local ac power network frequency

At the moment, leave the ac power source off. The ac power source will be turned on in the next section of the procedure.

Measuring the phase shift between two voltage sine waves in a resistor-inductor (RL) circuit

In this section, you will observe the waveforms (sine waves) of the source voltage U_s and the resistor voltage U_R to determine the phase shift between the two sine wave voltages. Then, you will use a phasor analyzer to measure the phase shift between the source voltage phasor and the resistor voltage phasor, and compare it to the phase shift determined from the voltage waveforms.



As you will see later, due to the presence of an inductor in the circuit, the circuit current lags behind the source voltage. As a result, the voltage U_R measured across the resistor is out of phase with respect to the source voltage U_s .

- In LVDAC-EMS, set meters U_1 and U_2 to measure the rms values of the source voltage U_S and voltage U_R across resistor R , respectively.



When doing measurements using the instruments in LVDAC-EMS, always select the continuous refresh option. This ensures the instruments display updated data at all times.

In LVDAC-EMS, turn the ac power source on. Readjust the ac power source voltage U_S (indicated by meter U_1) so that it is equal to 100 V.

- In LVDAC-EMS, display voltage U_S (input U_1) and voltage U_R (input U_2) on channels 1 and 2 of the oscilloscope, respectively. Set the time base so as to display at least two cycles of the waveforms. Place the traces of the two channels at the same vertical position.

- In LVDAC-EMS, use the oscilloscope to measure the period T of the source voltage U_S . Record the value below.



To obtain an accurate measurement, use the vertical cursors of the LVDAC-EMS oscilloscope to measure the period or any other time interval.

Period $T =$ _____ ms

Period $T = 20.05$ ms. The results are shown in the following figure.

Oscilloscope Settings
 Channel-1 Input..... U1
 Channel-1 Scale..... 50 V/div
 Channel-1 Coupling..... DC
 Channel-2 Input..... U2
 Channel-2 Scale..... 50 V/div
 Channel-2 Coupling..... DC
 Display Filtering..... On
 Show Cursors..... Vertical
 Trigger Type..... Software
 Time Base..... 5 ms/div
 Trigger Source..... Ch1
 Trigger Level..... 0
 Trigger Slope..... Rising

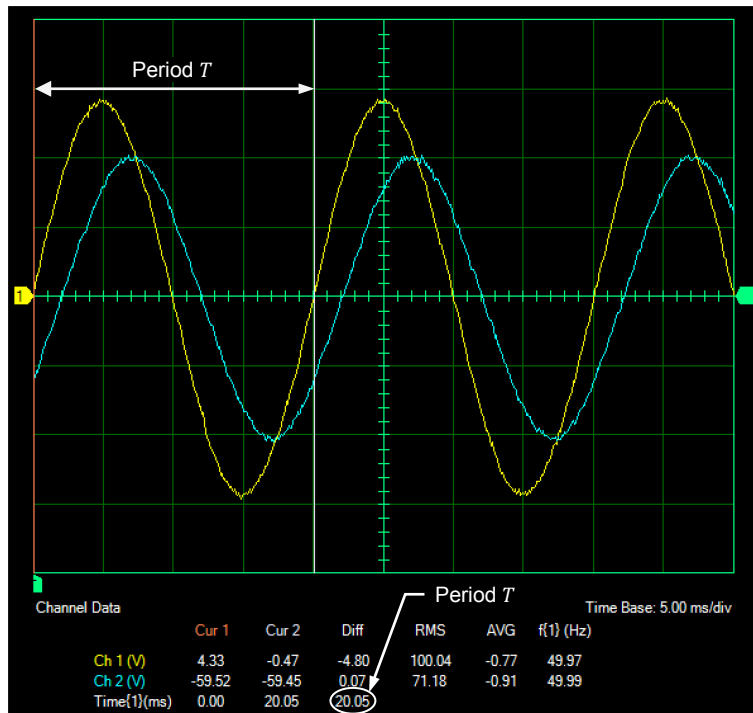

Period T of the waveform of the source voltage U_S at a frequency of 50 Hz.

9. In LVDAC-EMS, use the oscilloscope to measure the period T of the resistor voltage U_R . Record the value below.

Period $T =$ _____ ms

Period $T = 20.04$ ms. The results are shown in the following figure.

Oscilloscope Settings
 Channel-1 Input..... U1
 Channel-1 Scale..... 50 V/div
 Channel-1 Coupling..... DC
 Channel-2 Input..... U2
 Channel-2 Scale..... 50 V/div
 Channel-2 Coupling..... DC
 Display Filtering..... On
 Show Cursors..... Vertical
 Trigger Type..... Software
 Time Base..... 5 ms/div
 Trigger Source..... Ch1
 Trigger Level..... 0
 Trigger Slope..... Rising

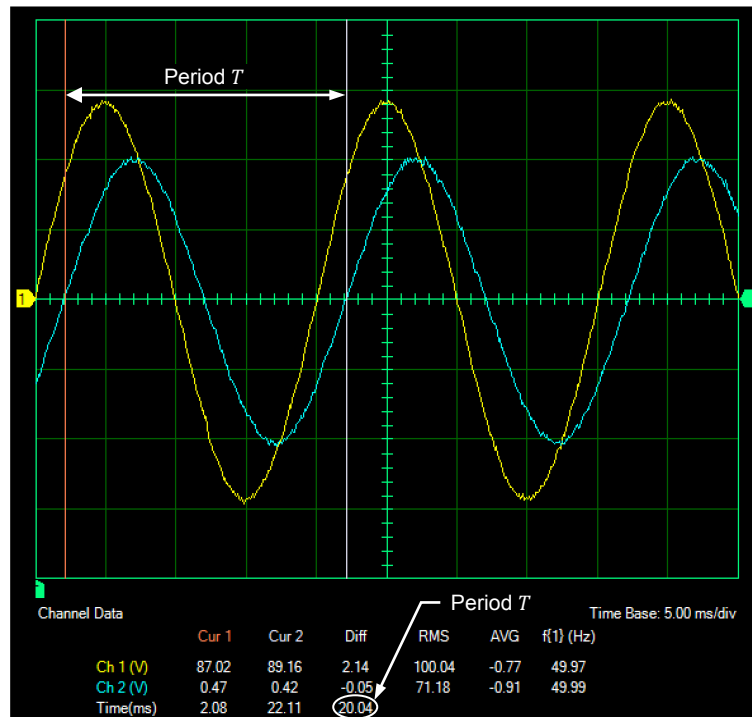

Period T of the waveform of the resistor voltage U_R at a frequency of 50 Hz.

10. Compare the period T of the resistor voltage U_R measured in the previous step with the period T of the source voltage U_S recorded in step 8. Are the values close to each other?

Yes No

Yes

11. In LVDAC-EMS, use the oscilloscope to measure the time interval d between the waveforms of the source voltage U_S and resistor voltage U_R . Record the value below.

Time interval $d =$ _____ ms

Time interval $d = 2.25$ ms. The results are shown in the following figure.

Oscilloscope Settings
 Channel-1 Input U1
 Channel-1 Scale 50 V/div
 Channel-1 Coupling DC
 Channel-2 Input U2
 Channel-2 Scale 50 V/div
 Channel-2 Coupling DC
 Display Filtering On
 Show Cursors Vertical
 Trigger Type Software
 Time Base 5 ms/div
 Trigger Source Ch1
 Trigger Level 0
 Trigger Slope Rising

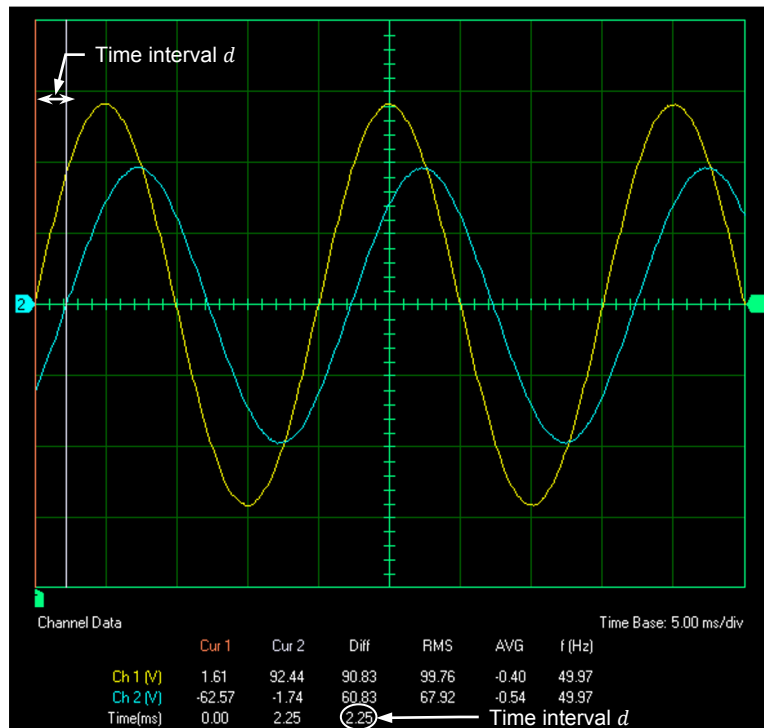

Time interval d between the waveforms of the source voltage U_S and resistor voltage U_R at a frequency of 50 Hz.

12. Using Equation (1-11), calculate the phase shift between the source voltage U_S and the resistor voltage U_R . Consider the source voltage waveform as the reference.

Phase shift = _____ °

$$\text{Phase shift} = \frac{d}{T} \cdot 360^\circ = \frac{2.25 \text{ ms}}{20.1 \text{ ms}} \cdot 360^\circ = 40.3^\circ$$

Phase shift = 40.3° lagging or -40.3°

13. Is the resistor voltage U_R leading or lagging the source voltage U_S ?

The resistor voltage U_R is lagging the source voltage U_S .

14. In LVDAC-EMS, use the phasor analyzer to display the phasors of source voltage U_S (input U1) and resistor voltage U_R (input U2). Select the source voltage U_S (input U1) as the reference phasor. Measure the phase angles θ_{U_S} and θ_{U_R} of the voltage phasors.

Phase angle θ_{U_S} = _____ °

Phase angle θ_{U_R} = _____ °

From these values, calculate the phase shift between the phasors of the source voltage U_S and resistor voltage U_R , using the source voltage phasor as the reference.

Phase shift = _____°

Phase angle $\theta_{U_S} = 0^\circ$

Phase angle $\theta_{U_R} = -42.07^\circ$

Phase shift = 42.07° lagging or -42.07°

15. Compare the phase shift you determined from the voltage sine waves to the phase shift you measured from the corresponding voltage phasors. Are both values close to each other?

Yes No

Yes

Measuring the phase shift between two voltage sine waves in a resistor-capacitor (RC) circuit

In this section, you will replace the inductor used in the previous section by a capacitor. You will use an oscilloscope to determine the phase shift between the two voltage sine waves. Then, you will use a phasor analyzer to measure the phase shift between the source voltage phasor and the resistor voltage phasor, and compare it to the phase shift you determined from the voltage waveforms.



As you will see later, due to the presence of a capacitor in the circuit, the circuit current leads the source voltage. As a result, the resistor voltage U_R is out of phase with respect to the source voltage U_S .

16. In LVDAC-EMS, turn the ac power source off.
17. Modify the circuit so that it is as shown in Figure 1-16 (replace the inductor by a capacitor). This circuit contains a resistor R and a capacitor C . Capacitors are studied in the next unit of this manual.

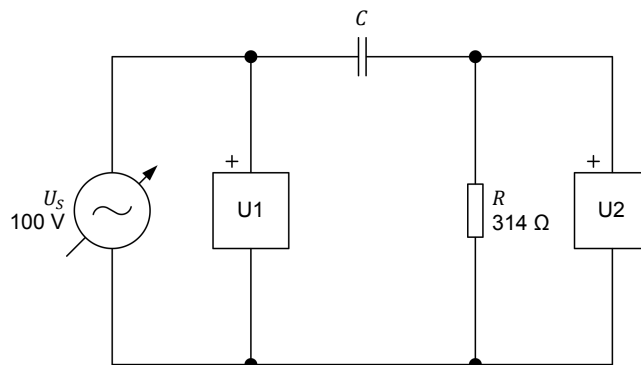



Figure 1-16. AC circuit with a resistor and a capacitor.

The value of capacitor C in the circuit of Figure 1-16 is referred to as the capacitance and is expressed in microfarads (μF). The capacitance value to be used is $5.06 \mu\text{F}$.

Make the necessary connections and switch settings on the **Resistive Load** in order to obtain the resistance values required.

 Appendix C of this manual lists the switch settings to implement on the **Resistive Load** in order to obtain various resistance values.

Make the necessary connections and switch settings on the **Capacitive Load** in order to obtain the capacitance value required.

 If necessary, ask your instructor to assist you to obtain the capacitance value required.

18. In **LVDAC-EMS**, turn the ac power source on. Readjust the ac power source voltage U_S (indicated by meter **U1**) so that it is equal to 100 V.

19. In **LVDAC-EMS**, use the oscilloscope to measure the period T of the source voltage U_S . Record the value below.

Period $T = \underline{\hspace{2cm}}$ ms

Period $T = 20.04$ ms. The results are shown in the following figure.

Oscilloscope Settings
 Channel-1 Input..... U1
 Channel-1 Scale..... 50 V/div
 Channel-1 Coupling..... DC
 Channel-2 Input..... U2
 Channel-2 Scale..... 50 V/div
 Channel-2 Coupling..... DC
 Display Filtering..... On
 Show Cursors..... Vertical
 Trigger Type..... Software
 Time Base..... 5 ms/div
 Trigger Source..... Ch1
 Trigger Level..... 0
 Trigger Slope..... Rising

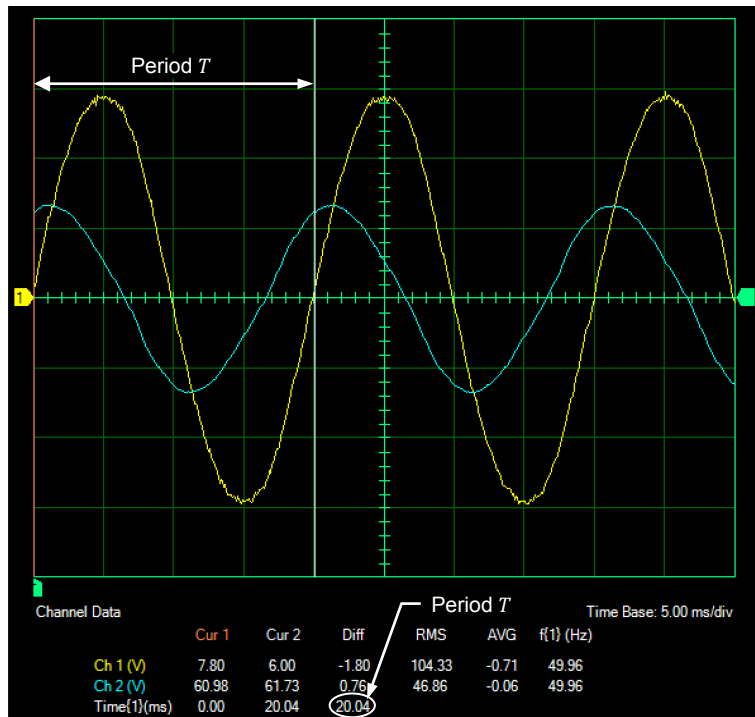

Period T of the waveform of the source voltage U_S at a frequency of 50 Hz.

20. In **LVDAC-EMS**, use the oscilloscope to measure the period T of the resistor voltage U_R . Record the value below.

Period $T = \underline{\hspace{2cm}}$ ms

Period $T = 20.04$ ms. The results are shown in the following figure.

Oscilloscope Settings
 Channel-1 Input..... U1
 Channel-1 Scale..... 50 V/div
 Channel-1 Coupling..... DC
 Channel-2 Input..... U2
 Channel-2 Scale..... 50 V/div
 Channel-2 Coupling..... DC
 Display Filtering..... On
 Show Cursors..... Vertical
 Trigger Type..... Software
 Time Base..... 5 ms/div
 Trigger Source..... Ch1
 Trigger Level..... 0
 Trigger Slope..... Rising

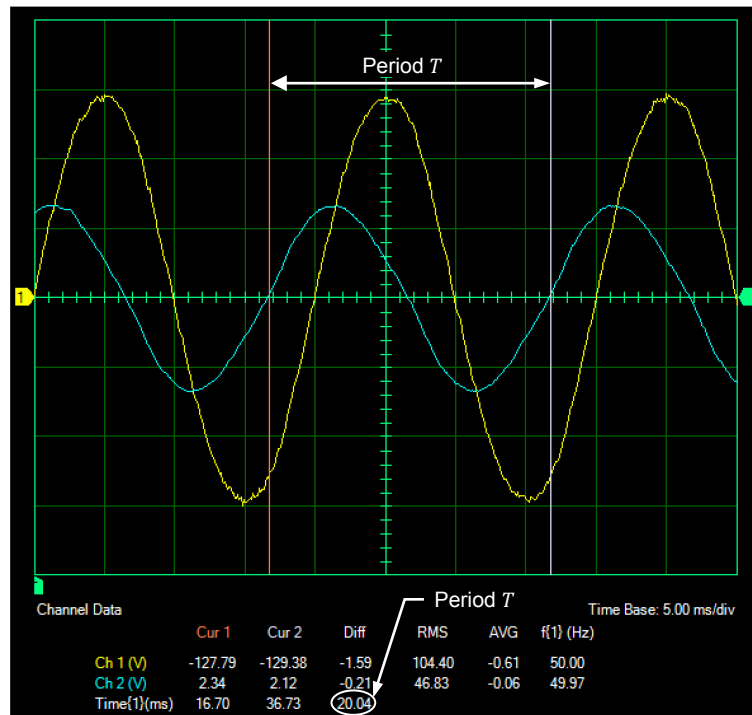

Period T of the waveform of the resistor voltage U_R at a frequency of 50 Hz.

21. Compare the period T of the resistor voltage U_R measured in the previous step with the period T of the source voltage U_S recorded in step 19. Are the values close to each other?

Yes No

Yes

22. In LVDAC-EMS, use the oscilloscope to measure the time interval d between the waveforms of the source voltage U_S and resistor voltage U_R . Record the value below.

Time interval $d =$ _____ ms

Time interval $d = 3.43$ ms. The results are shown in the following figure.

Oscilloscope Settings
 Channel-1 Input..... U1
 Channel-1 Scale..... 50 V/div
 Channel-1 Coupling..... DC
 Channel-2 Input..... U2
 Channel-2 Scale..... 50 V/div
 Channel-2 Coupling..... DC
 Display Filtering..... On
 Show Cursors..... Vertical
 Trigger Type..... Software
 Time Base..... 5 ms/div
 Trigger Source..... Ch1
 Trigger Level..... 0
 Trigger Slope..... Rising

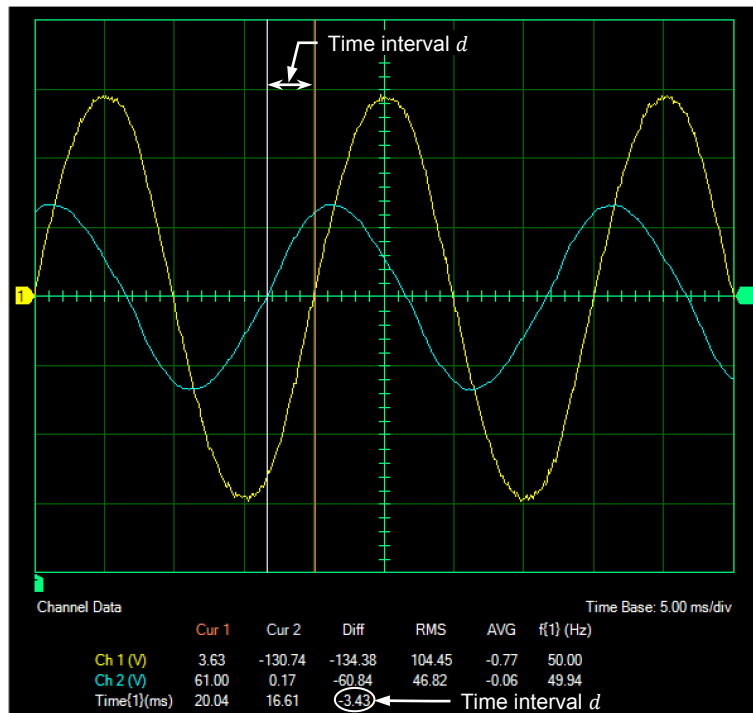

Time interval d between the waveforms of the source voltage U_S and resistor voltage U_R at a frequency of 50 Hz.

23. Using Equation (1-11), calculate the phase shift between the source voltage U_S and the resistor voltage U_R . Consider the source voltage waveform as the reference.

Phase shift = _____°

$$\text{Phase shift} = \frac{d}{T} \cdot 360^\circ = \frac{3.43 \text{ ms}}{20.0 \text{ ms}} \cdot 360^\circ = 61.7^\circ$$

Phase shift = 61.7° leading or 61.7°

24. Is the resistor voltage U_R leading or lagging the source voltage U_S ?

The resistor voltage U_R is leading the source voltage U_S .

25. In LVDAC-EMS, make sure that the source voltage U_S (input U1) is selected as the reference phasor in the phasor analyzer. Measure the phase angles θ_{U_S} and θ_{U_R} of the voltage phasors.

Phase angle θ_{U_S} = _____°

Phase angle θ_{U_R} = _____°

From these values, calculate the phase shift between the phasors of the source voltage U_S and resistor voltage U_R , using the source voltage phasor as the reference.

Phase shift = _____°

Phase angle $\theta_{U_S} = 0^\circ$

Phase angle $\theta_{U_R} = 63.17^\circ$

Phase shift = 63.17°

26. Compare the phase shift you determined from the voltage sine waves to the phase shift you measured from the corresponding voltage phasors. Are both values close to each other?

Yes No

Yes

27. In LVDAC-EMS, turn the ac power source off.
28. Close LVDAC-EMS.
29. Turn the 4 Quadrant Power Supply and Dynamometer Controller off.
30. Turn the AC 24 V Power Supply off.
31. Turn electric power off at your workstation, if applicable. Remove all circuit connections, finishing with the equipment earthing connections. Return all equipment to its storage location.

CONCLUSION

In this exercise, you saw how the phase angle modifies the value of a sine wave at time $t = 0$, and thus, the position in time of the sine wave. You observed the effects of positive and negative phase angles on the relative position in time of a sine wave. You were introduced to the notion of phase shift. You learned how to calculate and measure the phase shift between two sine waves and to differentiate between a lagging and a leading phase shift.

REVIEW QUESTIONS

1. What is the effect of the phase angle on the graphical representation of a sine wave?

The phase angle determines the value of a sine wave when $t = 0$ s, and thus, the position in time of the sine wave.

2. A sine wave has a phase angle θ of 72° . Will this sine wave reach its maximum value before, after or at the same time as a second waveform having a phase angle θ of -18° ?

The sine wave with the phase angle θ of 72° will reach its maximum value before the sine wave having a phase angle θ of -18° .

3. Given the following two sine wave equations:

$$U(t) = 8 \sin 20t + 78^\circ$$

$$U(t) = 40 \sin 20t + 43^\circ$$

Calculate the phase shift between these two sine waves, considering the first sine wave as the reference. Indicate also whether the second sine wave is lagging or leading the reference sine wave.

$$\text{Phase shift} = 43^\circ - 78^\circ = -35^\circ$$

The second sine wave is lagging the reference (first) sine wave.

4. When calculating the phase shift between two sine waves, which of the following parameters do the two sine waves need to have in common: phase angle, amplitude, frequency, or period? Why?

To calculate the phase shift between two sine waves, it is necessary for them to have the same frequency and period. Amplitude and phase angle have no effect on the duration of the sine wave cycle.

5. Consider two sine waves with the same frequency. They both have a period T of 50 ms. The second sine wave reaches its maximum positive value 8 ms after the first. Calculate the phase shift between the two sine waves, considering the first one as the reference.

$$\text{Phase shift} = \frac{d}{T} \cdot 360^\circ = \frac{8 \text{ ms}}{50 \text{ ms}} \cdot 360^\circ = 57.6^\circ$$

Since the second sine wave is lagging the reference, the value of the phase shift is negative, thus:

$$\text{Phase shift} = -57.6^\circ \text{ or } 57.6^\circ \text{ lagging}$$

Bibliography

Boylestad, Robert L., *Introductory Circuit Analysis*, 11th ed., Upper Saddle River: Prentice Hall, 2006, ISBN 978-0131730441.

Wildi, Theodore, *Electrical Machines, Drives, and Power Systems*, 6th ed., Upper Saddle River: Prentice Hall, 2005, ISBN 978-0131776913.